

Compact sewage disposal unit with cutting system pump

Sanipower

Conveying capacity

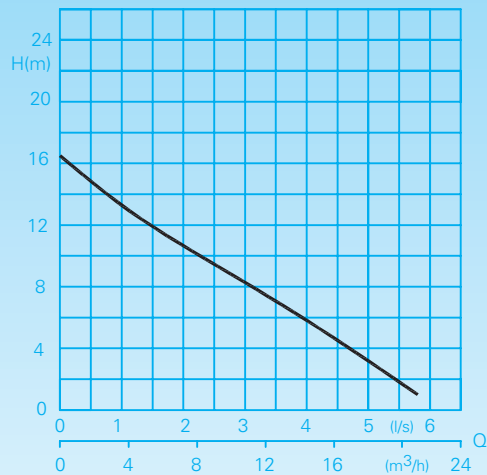
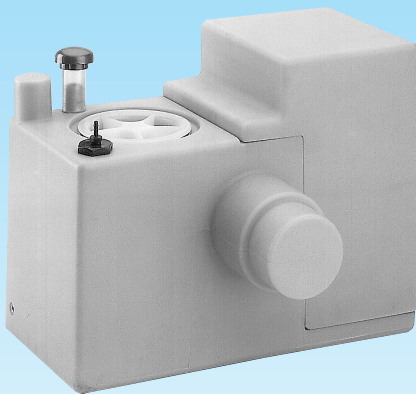

Application

Sanitary installations with WC, hand basins, washing machines and showers in basement apartments or cellars which are below sewer backflush level require the installation of a lifting station. The Sanipower is the ideal solution for this problem. With the advantage of a ground level direct WC connection, it is possible to place the Sanipower directly on to the back of the toilet. The reliable integrated stainless steel cutter system reduces to small pieces all soft solids from the waste water.

The diameter for the discharge pipe should be 1 ¼" minimum which can be easily laid at low cost with a minimum of construction work.

DIN EN 12050-3: Design tested and monitored.

Pumped medium: Drainage water, waste water or sewage. Max. liquid temperature: 35°C, short term up to 60°C.

Operating mode: Intermittent operation.

Design

Compact sewage disposal unit consisting of:

Collecting tank: Odour and gas-tight composite collection tank.

Max. utility volume 11 l. WC-inlet: DN 100 horizontal, inlet height 180 mm. Vertical inlet DN 50 on the top of the tank. Air vent DN 25 vertical. Cleaning cover with screw cap.

Pump: Single stage centrifugal pump with horizontal discharge. Open multi-channel impeller with cutting system. Discharge: BSP2" M.

Motor: Single-phase electric motor. Thermal sensor for temperature monitoring in the winding. Insulation class H. Protection rating IP 68. Chrome steel motor shaft, pre-lubricated bearings.

Seal: Combination of mechanical seals (siliconcarbide / siliconcarbide) and lip seal in oil chamber.

Control box: Pneumatic level control with pressure operation. Motor over run period which prevents sewage build up and blockage. Electronic control box for control and monitoring of all important functions. Motor protection with temperature control of the winding.

Optical failure alarm. Acoustic alarm by buzzer. Potential free malfunction alarms optionally retrofittable, see accessories. Control indication for direction of rotation.

- Monitoring of operation hours, number of starts, maintenance interval, abnormal operating conditions.
- Adjustment of pump operation level in the tank.

Material

Collecting tank	Plastic (PE)
Pump housing, motor housing, impeller	Cast iron
Cutting system	EN-GJL-250
Motor shaft, screws	Stainless steel 1.4528 (55 HRC)
Elastomers	Stainless steel
	NBR

Technical data

Motor input P ₁	1,4 kW
Motor input P ₂	1,0 kW
Voltage	230V/1Ph 50Hz
Rotational speed	2900 rpm
Nominal current	6,5 A
Connecting cable	H07RN8-F 4G1,5
Weight	32 kg
Discharge	G2

Scope of supply

Tank with pump, pneumatic electronic control box, 2 m of connecting cable and plug.

Installation example

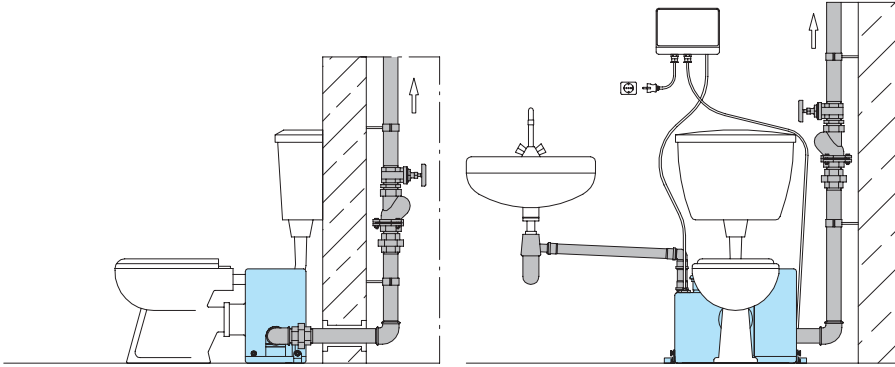

Accessories

Description	Size	Part no.
Gasket for WC-direct connection	Ø 134/87	2725134
Connection bend 90°, galvanized	BSP 2" F x BSP 1½" F	2112605
	BSP 2" F	2113606
Non-return valve, brass	BSP1½" F	2211313
Shut-off gate valve, brass	BSP1½" F	2216015
	BSP2" F	2216020
Transition screw connection, galvanized	BSP1½ M / F	2114305
	BSP2" F	2114311
Non-return ball valve, cast iron	BSP2" F	2212903
Alarm device AL3 with water level collecting tank		1586146
Potential free malfunction alarms		
Collective alarm-kit PCS1-SA-KIT		1964159
Accessories-Kit for retrofitting an mains-independent operation alarm signal consisting of:		1964160
- PCS1-SA-KIT		
- Alarm device AL3		
- Battery 9V for AL3		

Dimensions (all dimensions in mm)

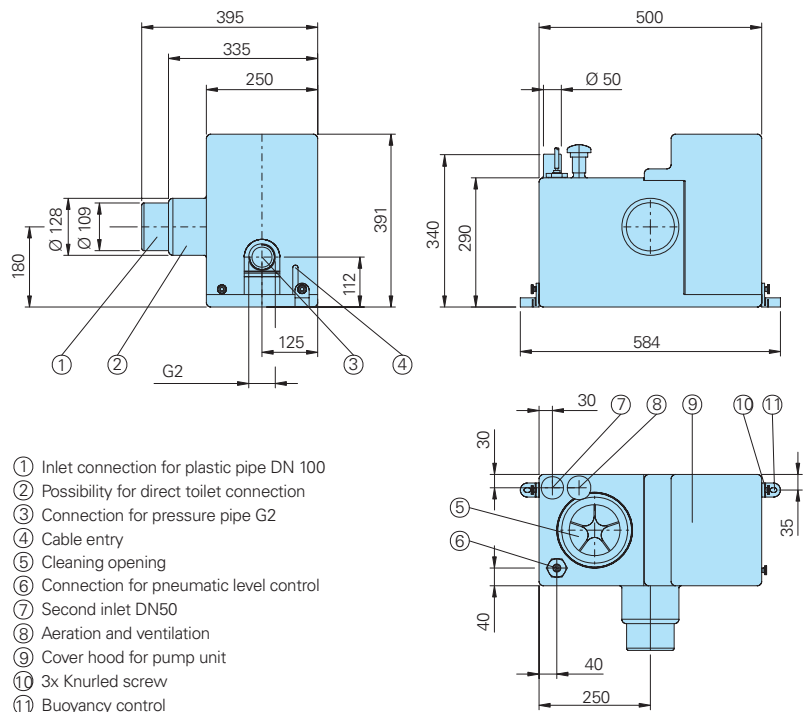

We reserve the right to alter our specifications without notice!